

GUIDE A ROTELLE

TRACK ROLLER GUIDES

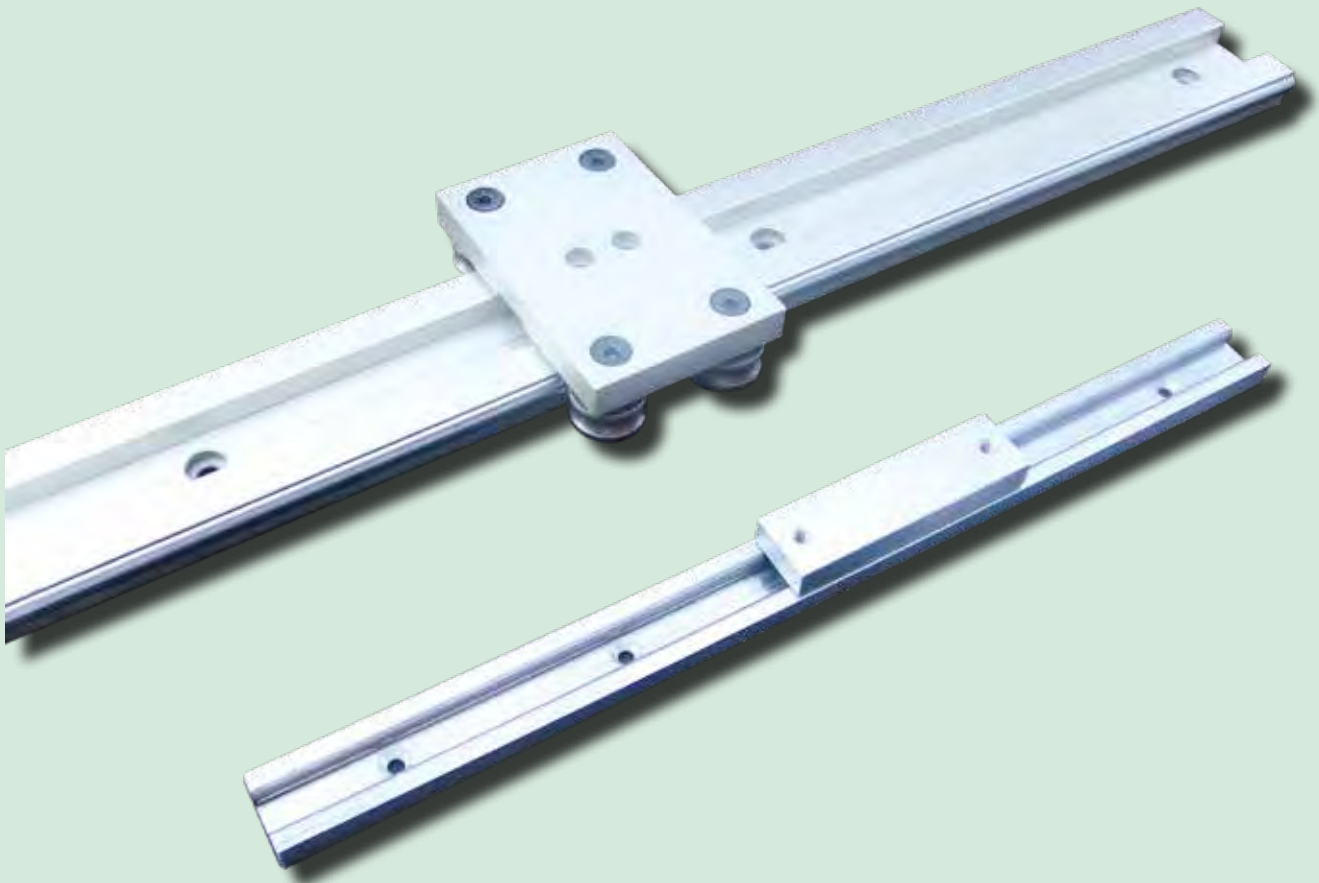

1. GUIDE DOPPIE "OUT LINE"
1. "OUT LINE" DOUBLE GUIDES

GD...

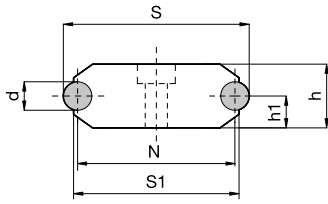

GDS...

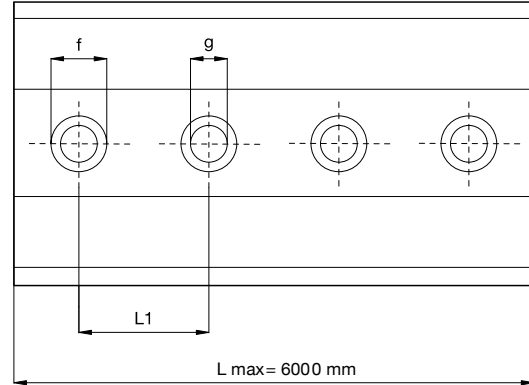
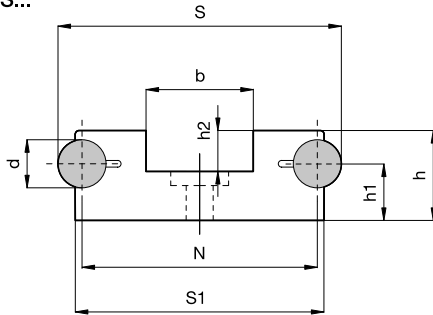

TIPOLOGIA TYPE	d mm	S mm	S1 mm	h mm	h1 mm	h2 mm	b mm	L1 mm	f mm	g mm	N mm
GD 8 L...	8	32	27,5	12	6	-	-	125	12	6,5	24
GD 10 L...	10	52	46,5	18	9	-	-	250	19	11	42
GDS 10 L...	10	70	63	20	13	11	27	250	19	11	60
GD 16 L...	16	95	84	24	12	-	-	250	19	11	79
GDS 16 L...	16	95	84	24	12	12	28	250	19	11	79
GDS 20 L...	20	95	80	30	18	18	34	250	19	11	75

N.B. A richiesta è possibile realizzare passi e tipologie di foratura speciali

NOTE Pitch and special holes available upon request

2. GUIDE SEMPLICI "OUT LINE"

GS...

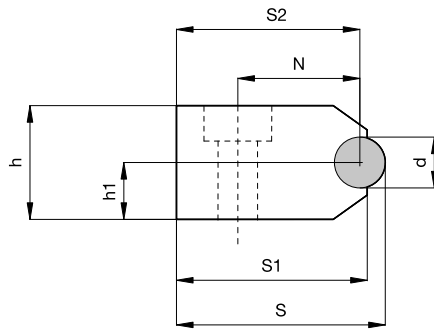

2. "OUT LINE" SINGLE GUIDES

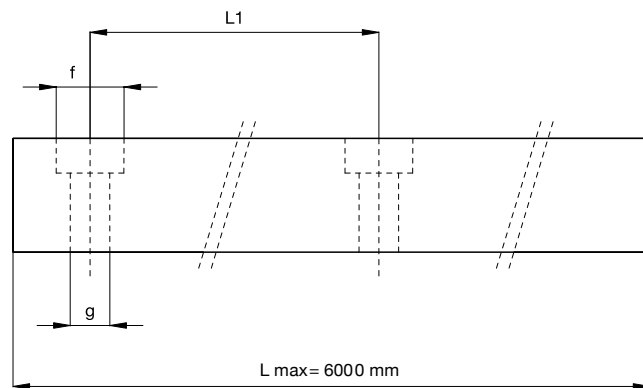

TIPOLOGIA TYPE	d mm	S mm	S1 mm	N mm	h mm	hi mm	L1 mm	f mm	g mm	S2 mm
GS 8 L...	8	26	24	16	12	6	125	12	6,5	22
GS 10 L...	10	42	39	26	18	9	250	19	11	37
GS 16 L...	16	45	39	30	24	12	250	19	11	37

N.B. A richiesta è possibile realizzare passi e tipologie di foratura speciali

NOTE Pitch and special holes available upon request

3. GUIDE "IN LINE"

Serie **C** Corpo centrale mobile
S Corpo centrale fisso

GL...

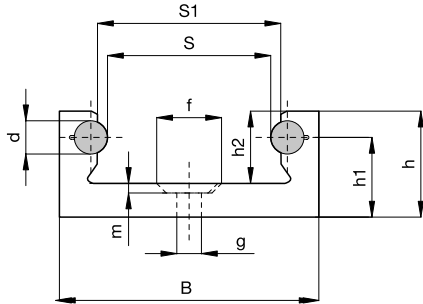

3. "IN LINE" GUIDES

Series **C** Mobile Central Part
S Fixed Central Part

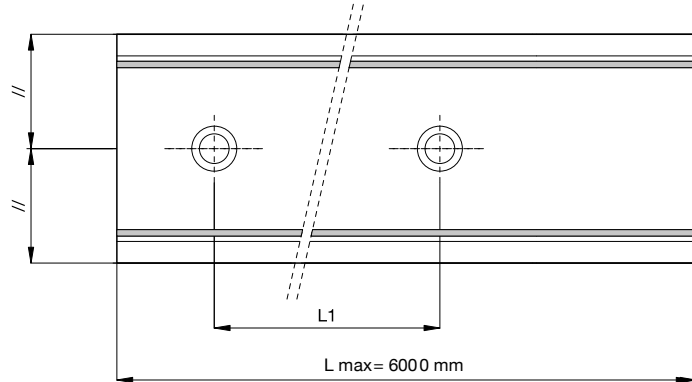

TIPOLOGIA TYPE	d mm	S mm	B mm	h mm	h1 mm	h2 mm	L1 mm	f mm	g mm	m mm	S1 mm
GLAS 28...	6	11	28	11,5	7,5	7,5	80	10	5,5	3	14,5
GLAS 43...	8	19,7	43	19	11,5	13,5	80	15	8,5	4,5	25,5
GLAC 63...	10	31,5	63	27	18,5	18	80	15	9	6	39,5
GLAS 63...	10	31,5	63	27	18,5	18	80	16	8,5	5	39,5

N.B. A richiesta è possibile realizzare passi e tipologie di foratura speciali

NOTE Pitch and special holes available upon request

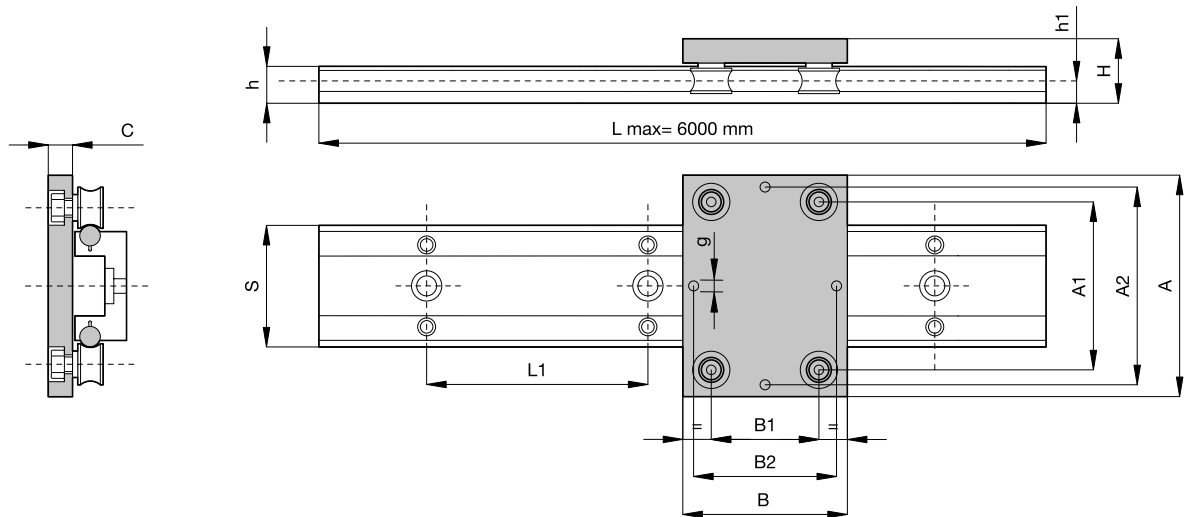

TIPOLOGIA CARRELLO BLOCK TYPE	TIPOLOGIA GUIDA RAIL TYPE	TIPOLOGIA ROTELLE TRACK ROLLER TYPE	A mm	B mm	C mm	H mm	S mm	A1 mm	A2 mm ± 0,2	B1 mm	B2 mm ± 0,2	L1 mm	g mm	h mm	h1 mm
CA 32,8 80 x 90	GD 8	RB/RBE 19,8	80	90	12,5	28	32	51	60	60	70	125	M8	12	6
CA 32,8 90 x 120	GD 8	RB/RBE 22,8	90	120	14,5	30	32	54	70	85	95	125	M8	12	6
CA 52,10 110 x 120	GD 10	RB/RBE 24,10	110	120	14,5	34	52	76	85	85	95	250	M8	18	9
CA 52,10 120 x 140	GD 10	RB/RBE 31,10	120	140	18	40	52	83	95	95	115	250	M10	18	9
CA 52,10 140 x 160	GD 10	RB/RBE 38,10	140	160	22	44	52	90	110	105	125	250	M10	18	9
CA 70,10 125 x 80	GDS 10	RB/RBE 24,10	125	80	14,5	38	70	94	96	45	55	250	M10	20	13
CA 70,10 160 x 120	GDS 10	RB/RBE 38,10	160	120	18	44	70	108	115	70	95	250	M10	20	13
CA 70,10 150 x 120	GDS 10	RB/RBE 31,10	150	120	18	43	70	101	115	80	115	250	M10	20	13
CA 95,16 170 x 200	GD/GDS 16	RB/RBE 31,16	170	200	22	47	95	126	145	155	175	250	M10	24	12
CA 95,16 185 x 220	GD/GDS 16	RB/RBE 38,16	185	220	22	47	95	133	150	170	190	250	M10	24	12
CA 95,16 210 x 265	GD/GDS 16	RB/RBE 50,16	210	265	23	50	95	145	180	200	235	250	M10	24	12
CA 95,20 185 x 150	GDS 20	RB/RBE 38,20	185	150	23	54	95	133	150	95	120	250	M10	30	18
CA 95,20 210 x 180	GDS 20	RB/RBE 50,20	210	180	23	56	95	145	170	115	135	250	M10	30	18
CA 95,20 210 x 265	GDS 20	RB/RBE 50,20	210	265	23	56	95	145	170	200	230	250	M10	30	18

4. CARATTERISTICHE DI CARICO DEI CARRELLI "OUT LINE"

4. "OUT LINE" CARRIAGE TECHNICAL CHARACTERISTICS

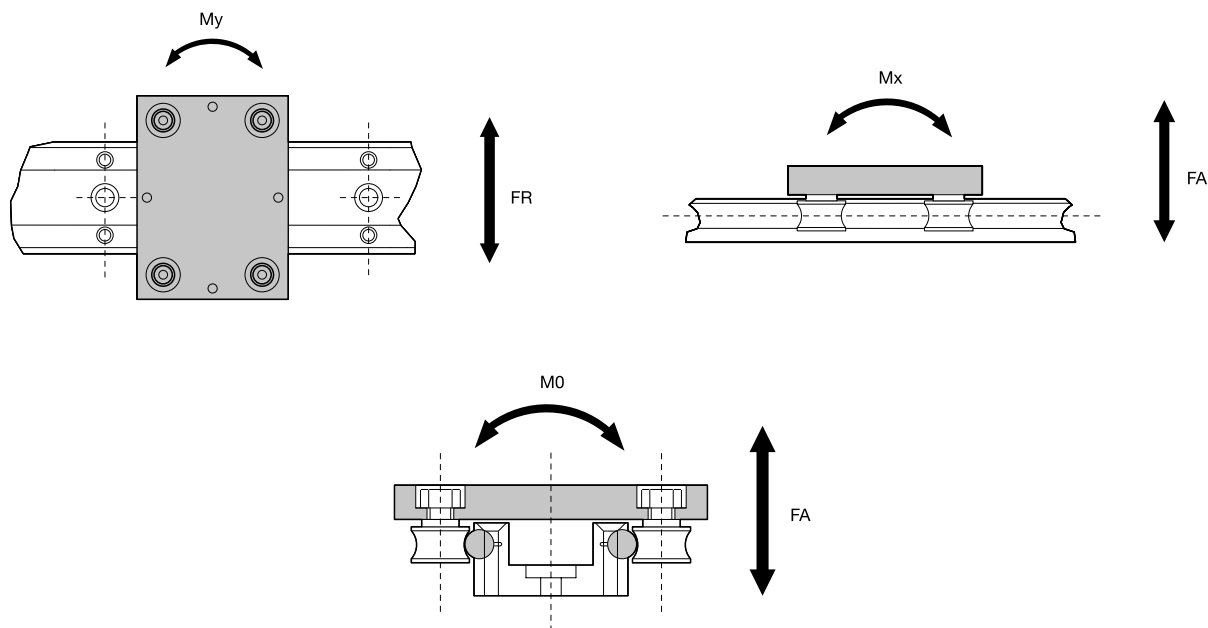

TIPOLOGIA CARRELLO BLOCK TYPE	TIPOLOGIA GUIDA RAIL TYPE	CARICO LIMITE MAX LOAD (N)		MOMENTO STATICO STATIC MOMENT (Nm)			VELOCITÀ SPEED (m/s)	PESO WEIGHT (Kg)
		FR	FA	MO	Mx	My		
CA 32,8 - 80 x 90	RB/RBE 19,8	1770	450	11	18	77	4	0,33
CA 32,8 - 90 x 120	RB/RBE 22,8	1770	450	13	23	85	6	0,49
CA 52,10 - 110 x 120	RB/RBE 24,10	2450	520	16	26	150	7	0,74
CA 52,10 - 120 x 140	RB/RBE 31,10	6450	1060	29	45	270	8	1,4
CA 52,10 - 140 x 160	RB/RBE 38,10	8820	1400	33	51	405	10	2,1
CA 70,10 - 125 x 80	RB/RBE 24,10	2450	520	20	26	150	7	0,63
CA 70,10 - 160 x 120	RB/RBE 38,10	8820	1400	37	58	303	10	1,84
CA 95,16 - 170 x 200	RB/RBE 31,16	6450	1060	40	70	432	9,5	2,7
CA 95,16 - 185 x 220	RB/RBE 38,16	8820	1400	56	84	675	10	3,3
CA 95,16 - 210 x 265	RB/RBE 50,16	9630	1870	68	106	1120	12	5,1
CA 95,20 - 185 x 150	RB/RBE 38,20	8820	1400	60	96	890	10	4,8
CA 95,20 - 210 x 180	RB/RBE 50,20	9630	1870	94	128	1360	12	6,8
CA 95,20 - 210 x 265	RB/RBE 50,20	9630	1870	94	140	1680	12	8,4

5. TABELLE DIMENSIONALI PATTINI PER GUIDE "IN LINE"

5. "IN LINE" CARRIAGE DIMENSIONS TABLE

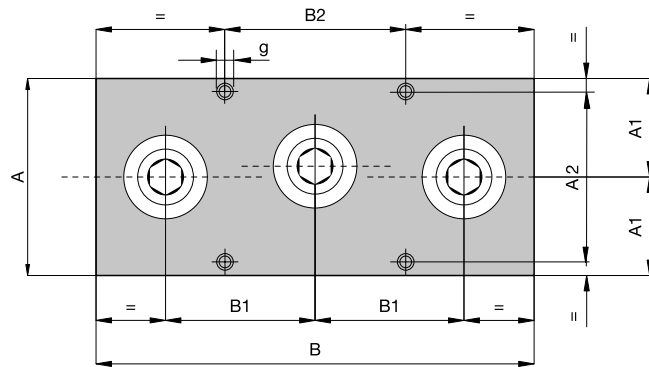
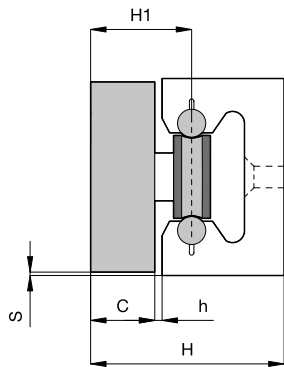

PA.,3

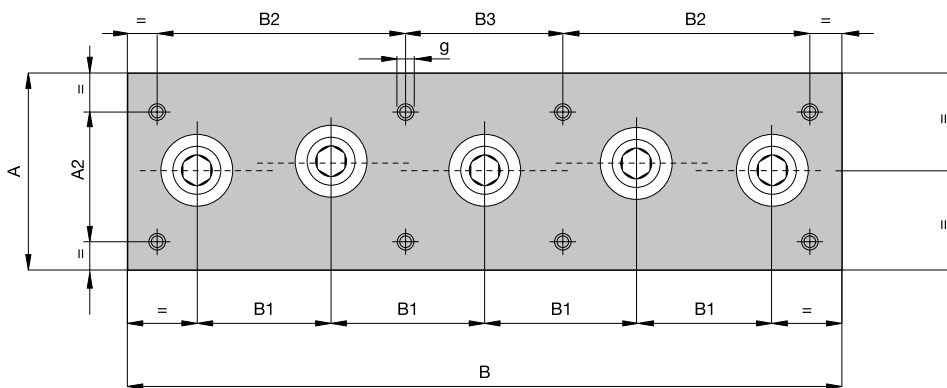

PA.,5

TIPOLOGIA TYPE	ROTELLE TRACK ROLLER N°	A mm	A1 mm	A2 mm ± 0,2	B mm	B1 mm	B2 mm ± 0,2	B4 mm ± 0,2	C mm	H mm	H1 mm	s mm	g mm	h mm	TIPOLOGIA ROTELLE TRACK ROLLER TYPE
PA 28,3	3	26,5	13,5	-	96	26	78	-	12	24	16,5	0,75	M6	0,5	R/RE 105,6
PA 43,3	3	40	20	24	130	42	114	-	16	37	25,5	1,5	M8	2	RB/RBE 19,8
PA 43,5	5	40	20	24	200	40	40	-	16	37	25,5	1,5	M8	2	RB/RBE 19,8
PA 63,3	3	60	30	34	190	65	168	-	19,5	51	32,5	1,5	M8	4,5	RB/RBE 31,10
PA 63,5	5	60	30	34	290	54	108	54	19,5	51	32,5	1,5	M8	4,5	RB/RBE 31,10

6. CARATTERISTICHE DI CARICO DEI PATTINI PER GUIDE "IN-LINE"

6. "IN LINE" CARRIAGE TECHNICAL CHARACTERISTICS

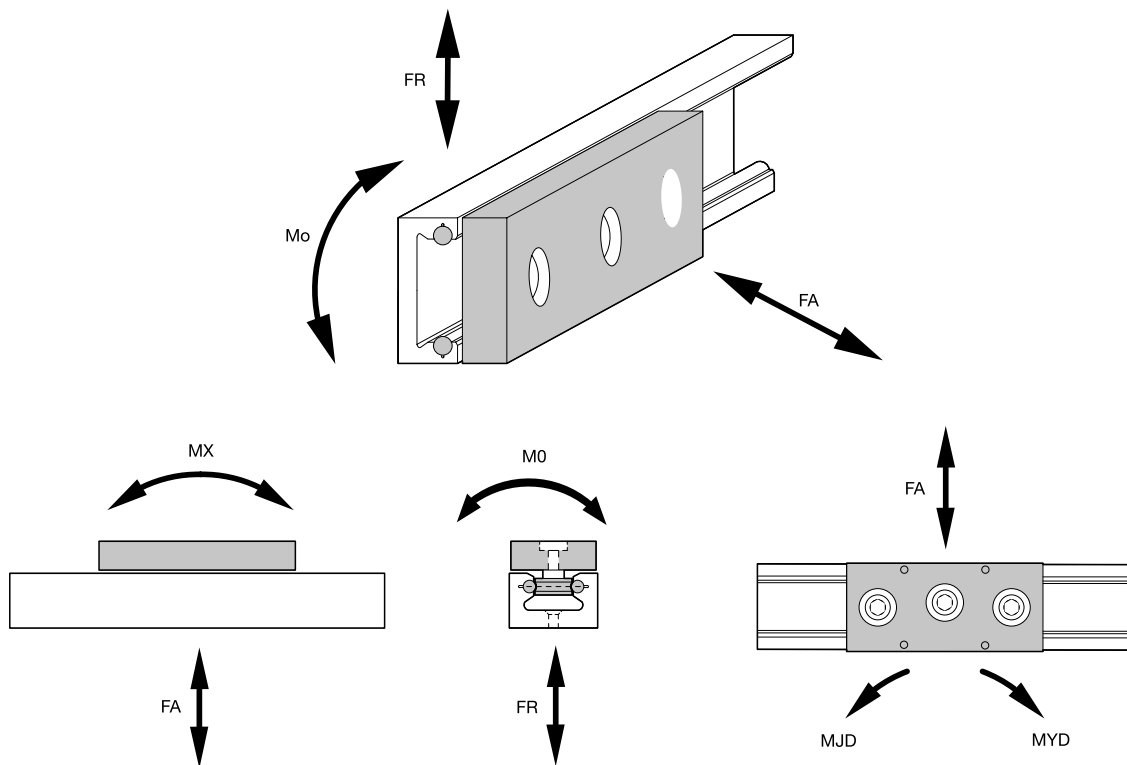

TIPOLOGIA CARRELLO BLOCK TYPE	CARICO LIMITE MAX LOAD (N)		MOMENTO STATICO STATIC MOMENT (Nm)				VELOCITÀ SPEED (m/s)	PESO WEIGHT (Kg)
	FR	FA	MO	Mx	Mjd	Myd		
PA 28,3	1720	330	4	7	21	21	3,5	0,15
PA 43,3	3600	710	14	32	82	82	6	0,3
PA 43,5	4380	1070	28	70	235	125	6	0,41
PA 63,3	6240	930	93	105	275	275	8	0,93
PA 63,5	9360	1560	180	380	815	420	8	1,4

7. ROTELLE

I nostri sistemi lineari scorrono su rotelle opportunamente sagomate e con perno folle.

Ogni rotella viene eseguita con perno concentrico ed eccentrico. Mediante le rotelle concentriche si ottiene il parallelismo tra carrello e guida, mentre con quelle eccentriche si eliminano i giochi residui e/o si può precaricare il sistema per ottenere uno scorrimento dolce o rigido a seconda delle necessità dell'applicazione.

Le rotelle sono composte da due cuscinetti schermati, inseriti in un anello esterno, realizzato in acciaio per cuscinetti temprato, con profilo ad arco gotico che assicura una guida precisa.

Possono essere fornite due tipologie di rotelle, che differiscono tra loro per il perno montato:

Rotella di tipo **A** con perno filettato esternamente

Rotella di tipo **B** con perno filettato internamente

Rotella Tipo A / A type track roller

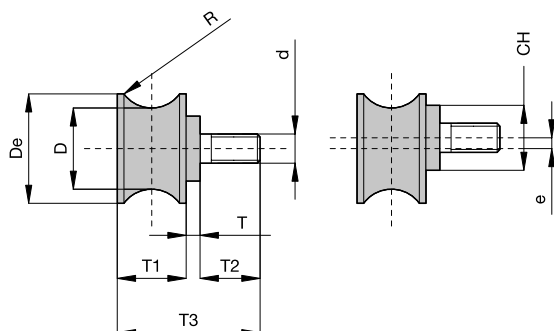

7. TRACK ROLLERS

This linear guides sliding system is based on profiled Track Rollers components with studs. Each track roller type can be assembled with concentric or eccentric stud. The concentric track roller can fix the parallelism between slide and rail, while the eccentric one compensates any clearance and allows to preload the linear system in order to perform a smooth movement or a rigid one, depending on the customer's demand. Each track roller includes two sealed bearings fitted into an outer ring made of bearing's steel, profiled with a gothic arch that can guarantee an accurate guidance system.

Two track roller types are available, depending on the type of stud:

A type track roller with stud externally threaded

B type track roller with stud internally threaded

Rotella Tipo B / B type track roller

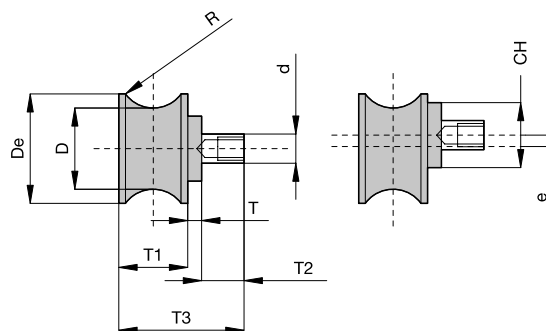

I coefficienti di carico dinamico e statico riportati, sono stati determinati secondo due sistemi di calcolo generalmente accettati per questo tipo di materiale.

The Dynamic and Static Load Capacities included into the technical characteristics have been calculated according the common standards relevant to this kind of items.

TIPOLOGIA TYPE		COEFF. DI CARICO (N) LOAD CAPACITY (N)		CARICO LIMITE ROTELLA TRACK ROLLER LOAD LIMIT (N)		
RA../RB..	RAE../RBE..	DINAMICO DYNAMIC	STATICO STATIC	RADIALE RADIAL		ASSIALE AXIAL
		C	Co	Fr	Fro	Fa
R 105,6	RE 105,6	1770	610	980	580	155
19,8	19,8	1770	610	980	580	155
22,8	22,8	1770	610	980	550	155
24,1	24,1	2750	990	1350	810	180
31,1	31,1	7390	3100	3900	2350	390
31,16	31,16	7390	3100	3900	2350	390
38,1	38,1	8120	3780	4860	2900	525
38,16	38,16	8120	3780	4860	2900	525
38,2	38,2	8120	3780	4860	2900	525
50,16	50,16	8950	4560	5290	3200	710
50,2	50,2	8950	4560	5290	3200	710

Per facilitare la registrazione, attraverso una chiave a brugola, ed il fissaggio della rotella sul carrello, il perno è munito di un collare esagonale nella parte inferiore.

In order to ease the adjustment and the fixing of the track roller on the slide, the stud is provided with a hex collar at the end.

7.1 TABELLA DIMENSIONALE ROTELLE

Rotella con Perno Tipo A / A type track roller with stud

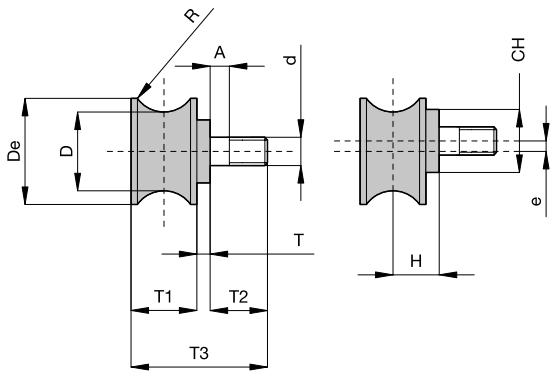
7.1. DIMENSION TABLE OF TRACK ROLLERS

Rotella con Perno Tipo B / B type track roller with stud

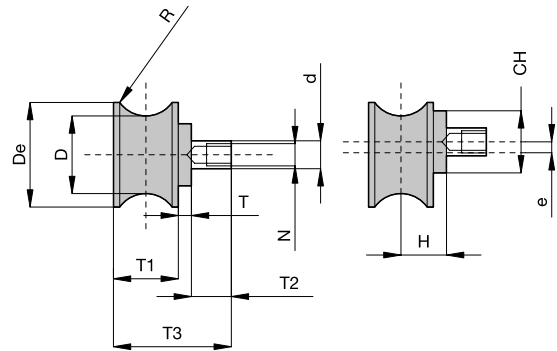

TIPOLOGIA / TYPE		PERNO TIPO A (DIMENSIONI PRINCIPALI mm) STUD TYPE A (MAIN DIMENSIONS mm)												
ROTELLA CONCENTRICA CONCENTRIC TRACK ROLLER	ROTELLA ECCENTRICA ECCENTRIC TRACK ROLLER	D albero D Shaft	D	De	d	CH	R	e	T3	T1	T2	T	H	A
R 105,6	RA 105,6	6	10,5	13	5	-	3	0,5	18	7	10,5	0,5	-	-
RA 19,8	RAE 19,8	8	19	22	M8	13	4	0,7	27,2	11	12	4	9,5	4
RA 22,8	RAE 22,8	8	22	24,5	M8	13	4	0,7	27,2	11	12	4	9,5	4
RA 24,10	RAE 24,10	10	24	28	M8	17	5	0,7	31,25	13,5	14	3,75	10,5	4
RA 31,10	RAE 31,10	10	31	36	M10	17	5	0,7	40	18	18	4	13	5
RA 31,16	RAE 31,16	16	31	36	M10	17	8	0,7	40	18	18	4	13	5
RA 38,10	RAE 38,10	10	38	44	M12	19	5	0,7	42	20	18	4	14	7
RA 38,16	RAE 38,16	16	38	44	M12	19	8	0,7	42	20	18	4	14	7
RA 38,20	RAE 38,20	20	38	44	M12	19	10	0,7	42	20	18	4	14	7
RA 50,16	RAE 50,16	16	50	56	M14	22	8	0,7	48	22	22	4	15	9
RA 50,20	RAE 50,20	20	50	56	M14	22	10	0,7	48	22	22	4	15	9

TIPOLOGIA / TYPE		PERNO TIPO B (DIMENSIONI PRINCIPALI mm) STUD TYPE B (MAIN DIMENSIONS mm)												
ROTELLA CONCENTRICA CONCENTRIC TRACK ROLLER	ROTELLA ECCENTRICA ECCENTRIC TRACK ROLLER	D albero D Shaft	D	De	d	CH	R	e	T3	T1	T2	T	H	A
RB 19,8	RBE 19,8	8	19	22	8	13	4	0,7	21,2	11	6	4	M6	9,5
RB 22,8	RBE 22,8	8	22	24,5	8	13	4	0,7	21,2	11	6	4	M6	9,5
RB 24,10	RBE 24,10	10	24	28	10	17	5	0,7	24,75	13,5	7,5	3,75	M8	10,5
RB 31,10	RBE 31,10	10	31	36	13	19	5	0,7	31	18	9	4	M10	13
RB 31,16	RBE 31,16	16	31	36	13	19	8	0,7	31	18	9	4	M10	13
RB 38,10	RBE 38,10	10	38	44	13	19	5	0,7	35	20	11	4	M10	14
RB 38,16	RBE 38,16	16	38	44	13	19	8	0,7	35	20	11	4	M10	14
RB 38,20	RBE 38,20	20	38	44	13	19	10	0,7	35	20	11	4	M10	14
RB 50,16	RBE 50,16	16	50	56	15	22	8	0,7	38	22	12	4	M12	15
RB 50,20	RBE 50,20	20	50	56	15	22	10	0,7	38	22	12	4	M12	15